

Maison Air et Lumière

VELUX®

MODEL
HOME 2020



Architectural concept



Address
35 chemin des Justices
91370 Verrières-le-Buisson
France

Photos of Maison Air et Lumière
Adam Mørk

Illustrations of Maison Air et Lumière
Cenário

Other photos and illustrations
The VELUX Group

Maison Air et Lumière is based on a modular architectural concept of the pitched roof, enabling it to be adapted to different contexts depending on the house's location, orientation and use. The house combines three volumes fitted into one another, a design that contributes to the quality and variety of the interior. The pitched roof is part of France's cultural heritage. Roof pitches vary in steepness according to region and climate – and to meet the need for light and solar gain. This also allows a wide variety of interior spaces to suit personal preferences.

Architectural concept

The architecture of Maison Air et Lumière is adapted harmoniously to its site. The slope of the site is used to organise the floor levels, creating an intermediate level between the garden level and the upper floor. In addition to this integration to the site, the modular concept of the house allows adaptation to create variants to suit other contexts, such as terraced or urban houses. Whether the house is small or large, in town or in the country, the flexibility of the concept enables the type and number of modules to be varied, making it possible to transpose the principles of comfortable living, energy efficiency and environmental quality of Maison Air et Lumière to a wide range of contexts. The 130 m² floor area extends over one and a half storeys, with the spaces under the roof put to full use. Maison Air et Lumière, using a design principle that integrates architectural quality and energy efficiency, manages to place the emphasis on interior comfort whilst respecting the energy and environmental objectives for new detached houses for 2020.

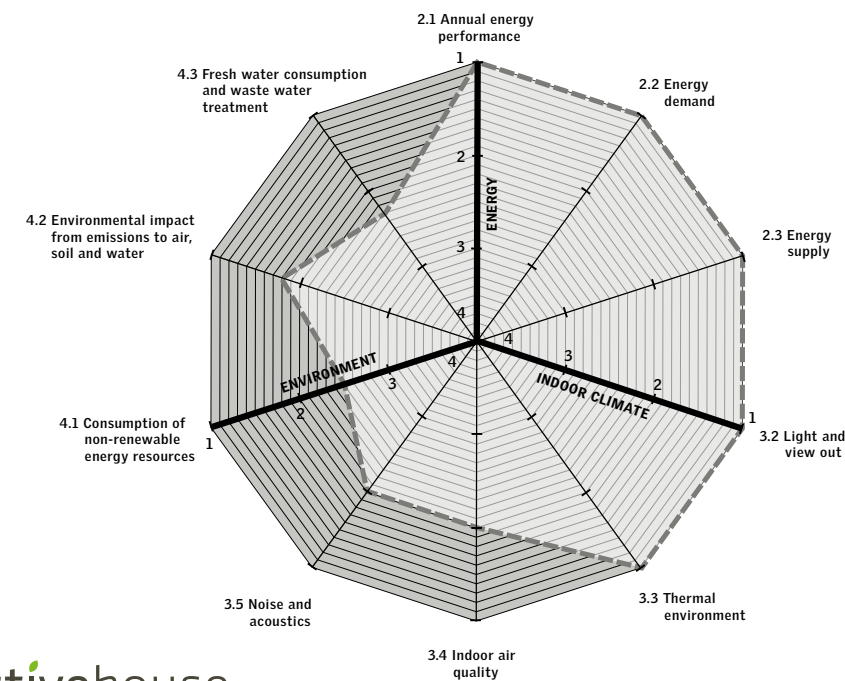
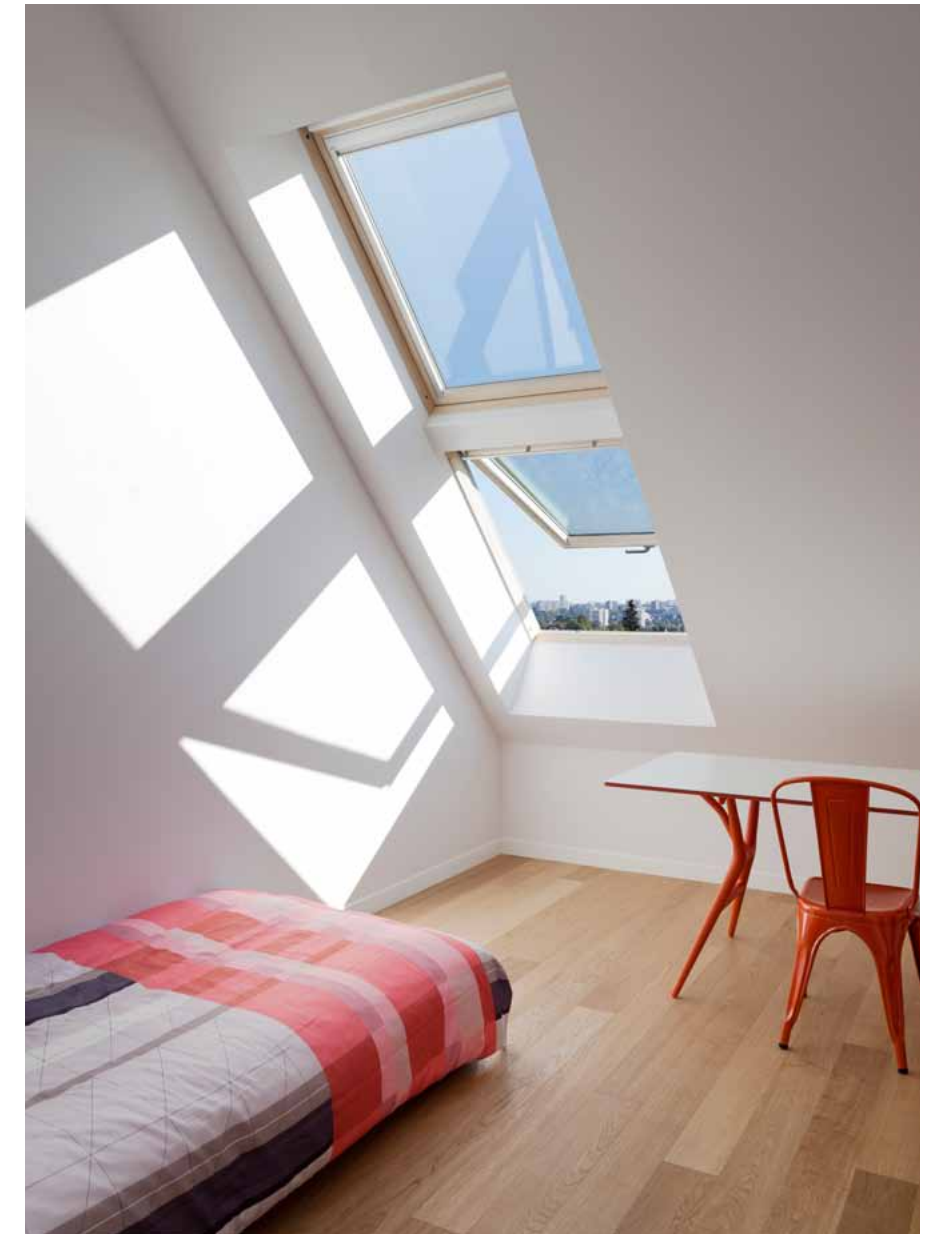

Active House principles

Maison Air et Lumière complies with the Active House principles where the three main principles of energy, indoor climate and environment are actively integrated in the design of buildings. This Active House radar shows how all parameters within each principle are balanced against each other, enabling the holistic approach and overview to sustainable buildings.

First edition for Active House radar diagram evaluation, based on Specification 1.0 published in April 2011. The radar diagramme shown is based on as well theoretical assumptions and calculations based on input from the project team, and generalised. The evaluation reflects work in progress.

Active House is an initiative supported by the VELUX Group.

Follow the project, visit www.velux.com/modelhome2020



Prizes and mentions

Maison Air et Lumière

The Maison Air et Lumière website, www.maisonairlumiere.fr, was awarded by Batiactu as the best 2011 online communication project in its category. Batiactu is a French daily on-line media providing a broad information overview of the building sector news.

The FIMBACTE Festival is a yearly professional event for experience sharing on projects dealing with urban development, sustainable buildings and cities. During the 2011 edition, Maison Air et Lumière was nominated, among 26 projects in the category for innovative projects, for the final selection of the '2011 Trophées du Cadre de vie'.

BBC Effinergie certification issued by CEQUAMI.

Daylight

Particular attention has been paid to daylight to ensure the physical and psychological health and well-being of the residents, and to enlarge the visual perception of the indoor spaces whilst saving energy by reducing the need for artificial lighting. The amount of daylight and the quality of its distribution have been studied scientifically using VELUX Daylight Visualizer 2.

Ventilation

According to the season and weather conditions, ventilation is provided by a hybrid system that combines the advantages of mechanical ventilation with heat recovery in winter and, in summer, natural ventilation by window opening (supplemented by mechanical extraction in bathroom and kitchen).

Daylight levels

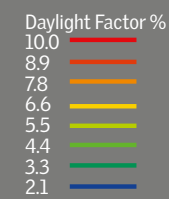

Ground floor



First floor

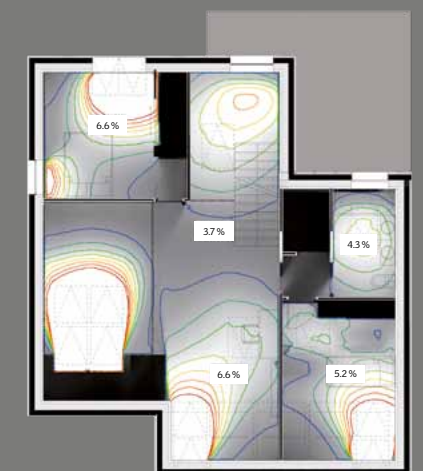

Energy concept

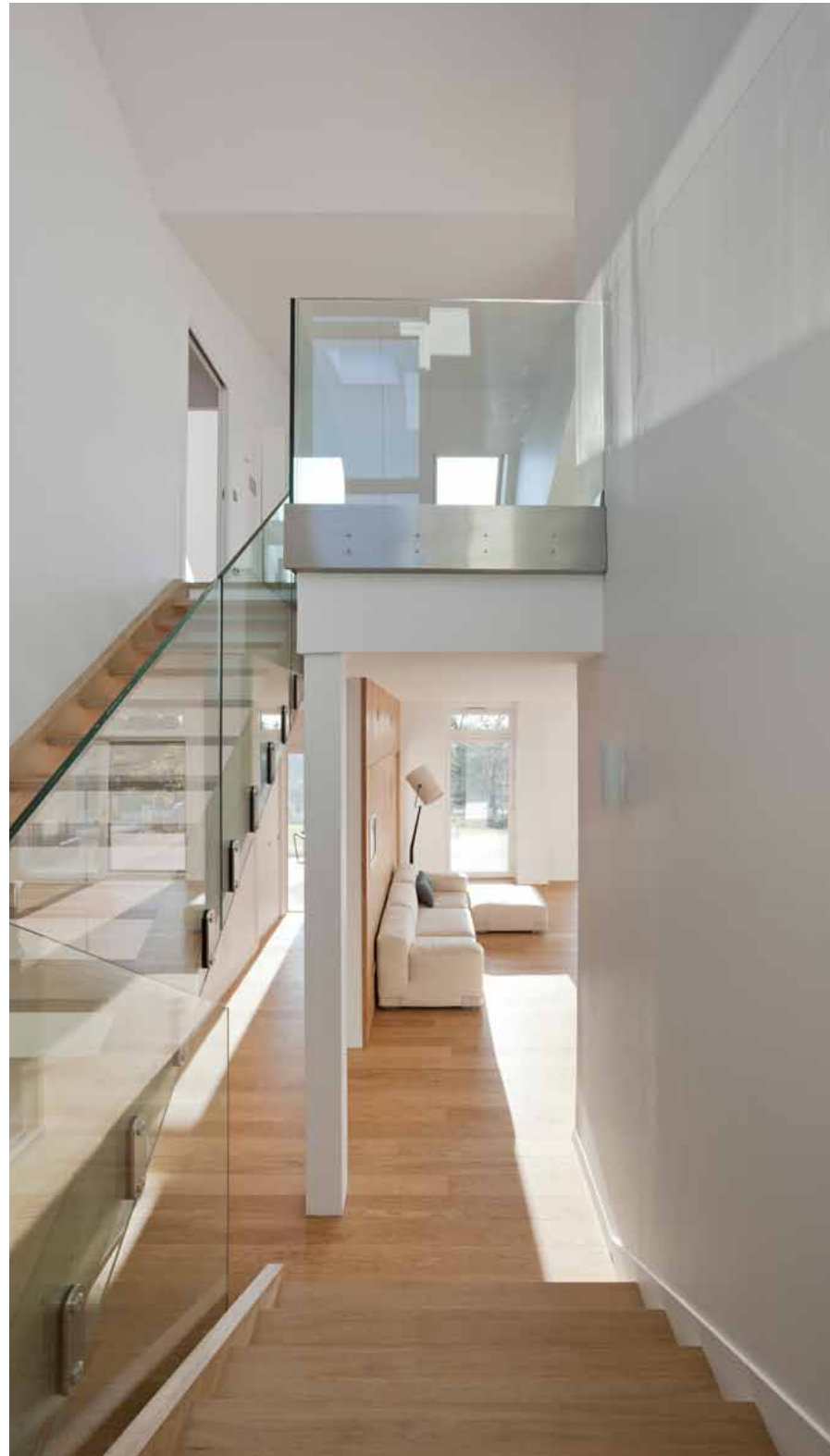

Energy design

The energy concept of Maison Air et Lumière is based on the maximum use of renewable resources (solar energy, natural light, fresh air) in order to minimise the need for air-conditioning in summer, to reduce heating in winter and to reduce artificial lighting. The combination means a neutral environmental impact and maximum comfort for the residents.

The house, which is built on a concrete slab on an earth platform insulated on the underside, is constructed with a well-insulated wooden frame and with a window-floor ratio of nearly 1:3 (calculated according to national standards).

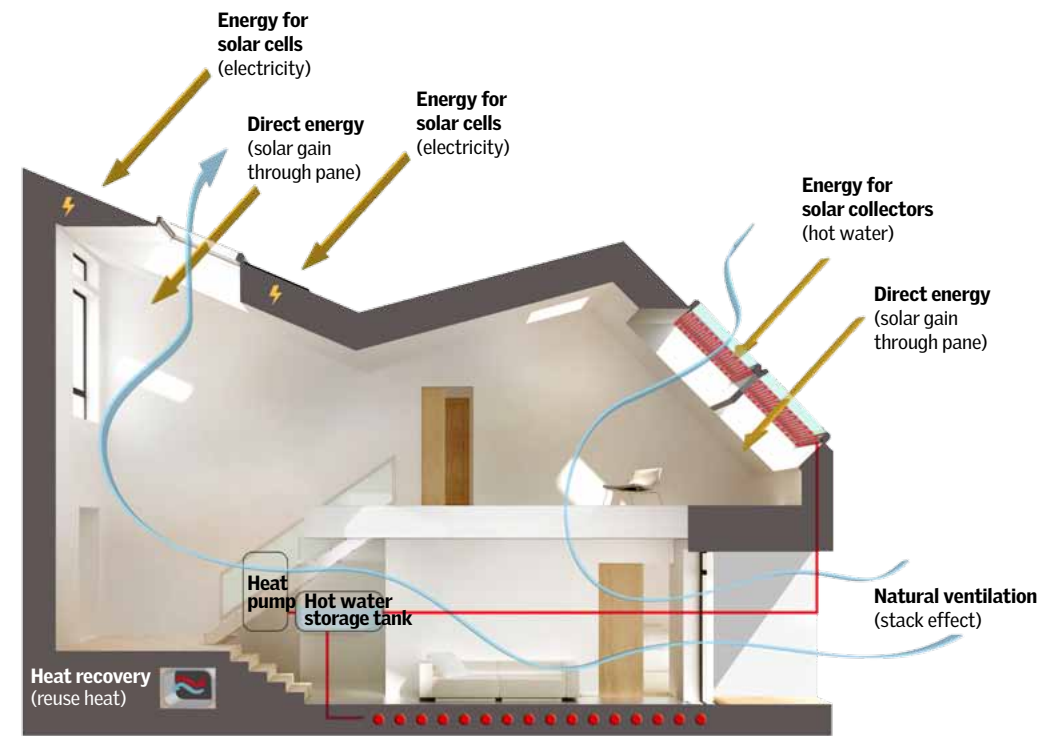

With its interplay of roof structures, the building is compact and very well insulated and, in order to create a stable and comfortable room temperature, the interior walls are lined with terracotta tiles, appreciably improving the thermal inertia of the building. The efficiency of the insulation combined with the recovery of free internal heat and solar gains through the windows will make it possible to reduce the heating demand to a minimum. Heating and hot water are

provided by a heat pump connected to VELUX thermal solar panels and a low-temperature underfloor heating system.

The artificial lighting, domestic appliances and multimedia equipment were selected on the basis of their low consumption. Moreover, to reduce electricity consumption further, the washing machine and dishwasher can be directly connected to a cold and hot water inlet.

All electric power consumption will be offset by the contribution from 35 m² of photovoltaic panels integrated in the roof. In normal use of the building, the overall energy balance is positive.

Net energy balance

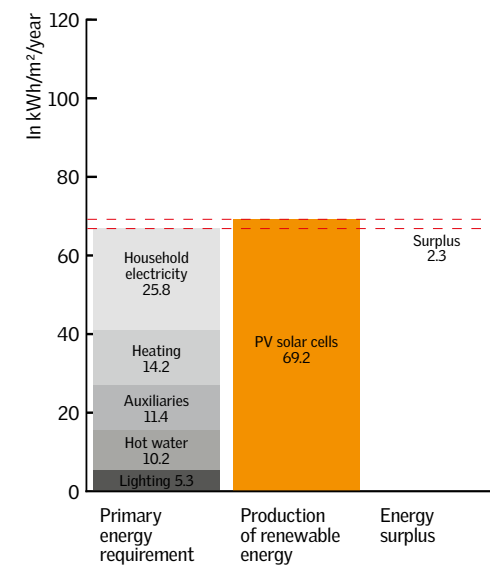

CO₂ balance

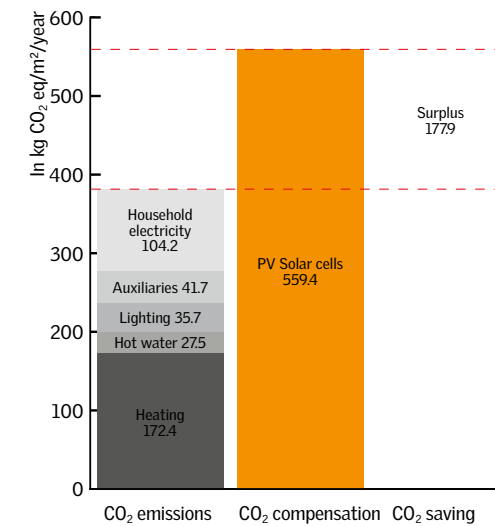

The calculation of the energy performance and production has been made according to national standards.

Products

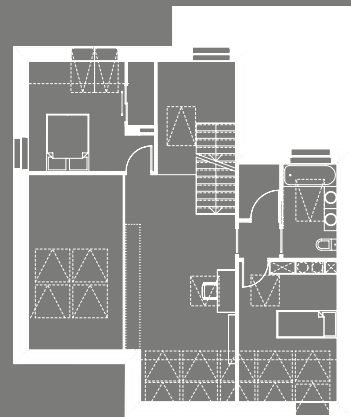

First floor



Ground floor

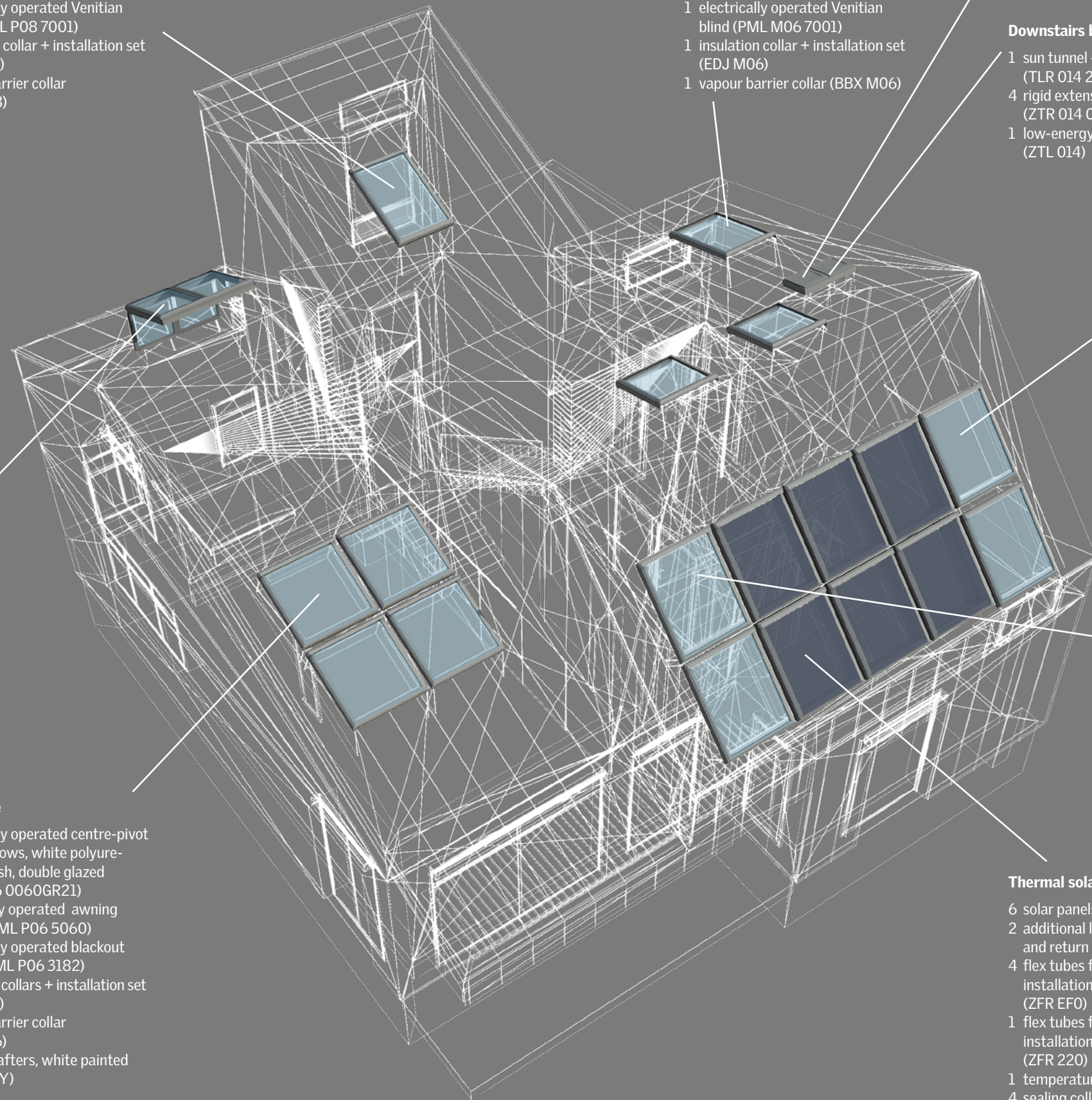

Entrance hall

- 1 electrically operated centre-pivot roof window, white polyurethane finish, double glazed (GGU P08 0060GR21)
- 1 electrically operated roller shutter (SML P08)
- 1 electrically operated Venetian blind (PML P08 7001)
- 1 insulation collar + installation set (EDJ P08)
- 1 vapour barrier collar (BBX P08)

Upstairs bathroom

- 1 electrically operated centre-pivot roof window, white polyurethane finish, double glazed (GGU M06 0973G21)
- 1 electrically operated awning blind (MML M06 5060)
- 1 electrically operated Venetian blind (PML M06 7001)
- 1 insulation collar + installation set (EDJ M06)
- 1 vapour barrier collar (BBX M06)

Downstairs WC

- 1 sun tunnel – rigid tube (TLR 014 2010)
- 4 rigid extension sections (ZTR 014 0124)
- 1 low-energy light kit (ZTL 014)

Downstairs bathroom

- 1 sun tunnel – rigid tube (TLR 014 2010)
- 4 rigid extension sections (ZTR 014 0124)
- 1 low-energy light kit (ZTL 014)

South-facing bedroom

- 1 electrically operated centre-pivot roof window, wood finish, double glazed (GGL S08 3060GR21)
- 1 electrically operated blackout blind (DML S08 1025)
- 1 top-hung roof window, wood finish, double glazed (GPL S08)
- 1 pleated blind (FHC S08)
- 2 electrically operated awning blinds (MML S08 5060)
- 2 insulation collars + installation set (EDJ S08)
- 2 vapour barrier collars (BBX S08)
- 1 support rafter, white painted finish (EKY)
- 1 electrically operated centre-pivot roof window, wood finish, double glazed (GGL M06 3073G21)
- 1 electrically operated awning blind (MML M06 5060)
- 1 electrically operated blackout blind (DML M06 1025)
- 1 insulation collar + installation set (EDJ M06)
- 1 vapour barrier collar (BBX M06)

North-facing bedroom

- 2 electrically operated roof windows, wood finish, double glazed (GGL M06 3973G21)
- 2 electrically operated awning blinds (MML M06 5060)
- 2 electrically operated blackout blinds (DML M06)
- 2 vapour barrier collars (BBX M06)
- 2 vertical windows (VFE M34 3073G)
- 2 solar powered blackout blinds (DSL M04 1025)
- 2 vapour barrier collars (BBX W34)

Guest suite

- 4 electrically operated centre-pivot roof windows, white polyurethane finish, double glazed (GGU P06 0060GR21)
- 4 electrically operated awning blinds (MML P06 5060)
- 4 electrically operated blackout blinds (DML P06 3182)
- 4 insulation collars + installation set (EDJ P06)
- 4 vapour barrier collar (BBX P06)
- 2 support rafters, white painted finish (EKY)

Mezzanine

- 2 electrically operated centre-pivot roof windows, wood finish, double glazed (GGL S08 3060GR21)
- 1 electrically operated blackout blind (DML S08 1025)
- 1 pleated blind (FHL S08 1016)
- 2 electrically operated awning blinds (MML S08 5060)
- 2 insulation collars + installation set (EDJ S08)
- 2 vapour barrier collars (BBX S08)
- 1 support rafter, white painted finish (EKY)
- 1 electrically operated centre-pivot roof windows, wood finish, double glazed (GGL M06 3073G21)
- 1 electrically operated awning blind (MML M06 5060)
- 1 electrically operated blackout blind (DML M06 1025)
- 1 insulation collar + installation set (EDJ M06)
- 1 vapour barrier collar (BBX M06)

Thermal solar energy

- 6 solar panels (CLI S08 4000)
- 2 additional length flexible flow and return pipes (ZFM 020)
- 4 flex tubes for side-by-side installation of collectors (ZFR EFO)
- 1 flex tubes for side-by-side installation of collectors (ZFR 220)
- 1 temperature sensor (ZPT 1000)
- 4 sealing collars (ZFT 0003)

System solution

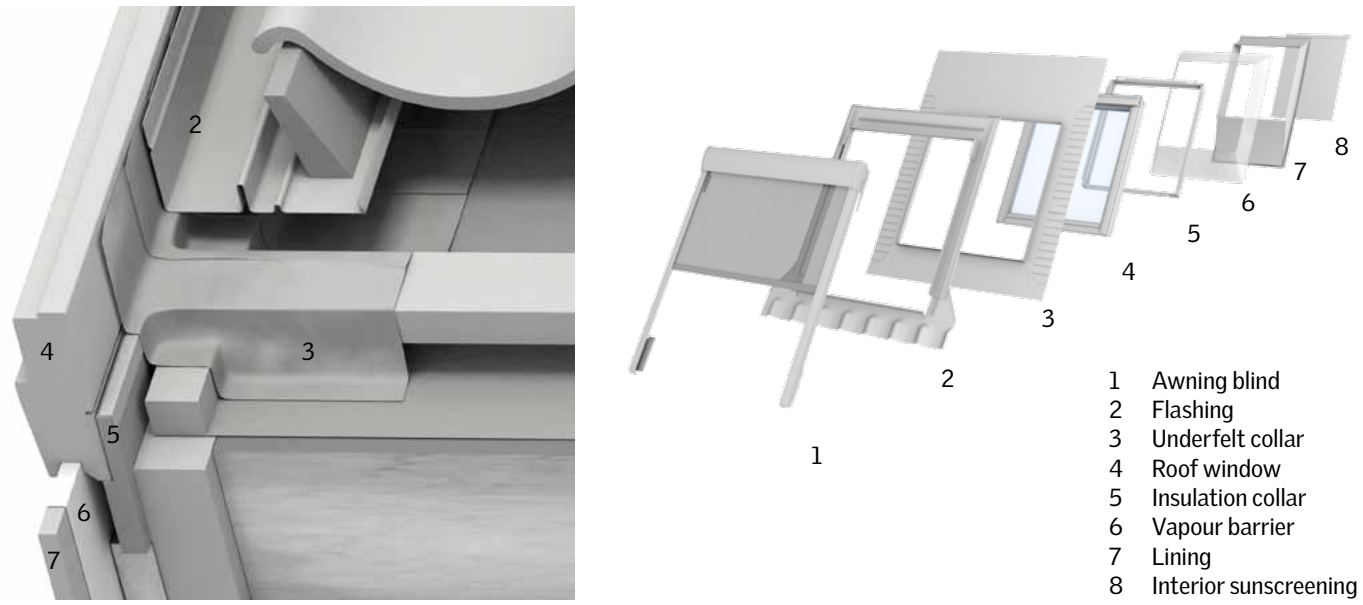

- 1 Awning blind
- 2 Flashing
- 3 Underfelt collar
- 4 Roof window
- 5 Insulation collar
- 6 Vapour barrier
- 7 Lining
- 8 Interior sunscreening

Figures

The chart shows the technical characteristics of the VELUX roof windows in relation to heat loss, passive heat gain and daylight. The heat loss (U_w) of the roof windows is influenced by the roof pitch. The heat gain (g-value) and light transmittance (Tau) are not affected by the orientation or roof pitch.

Roof windows with pane --73

Roof pitch	90°	23° and 45° (South)	15° and 25° (North)
U_w (Heat loss U-value window)	1.3 W/m ² K	1.3 W/m ² K	1.3 W/m ² K
U_g (Heat loss U-value pane)	1.1 W/m ² K	1.1 W/m ² K	1.1 W/m ² K
g (Heat gain g-value)	0.29	0.29	0.56
Tau (Light transmittance)	0.62	0.62	0.77

Outer walls

U (Heat loss U-value) 0.124 W/m²K (300 mm insulation)

Roof

U (Heat loss U-value) 0.098 to 0.105 W/m²K depending on roof pitch (500 mm insulation)

Floor slab

U (Heat loss U-value) 0.129 W/m²K (230 mm insulation)

Fenestration

Glass area 46 m²

Gross floor area (according to ISO 9836) 174 m²

Net floor area (according to French national standard) 135 m²

The window area is equivalent to 33 % of the habitable area according to French national standard.



Project partners

nomade
architectes

étha

CARDONNEL Ingénierie
le confort durable du bâtiment

Group partners

Window Master

Sonnenkraft
forever clever

Product partners

SAINT-GOBAIN

GLASSOLUTIONS SAINT-GOBAIN

ISOVER
SAINT-GOBAIN

SAINT-GOBAIN SOLAR

Placo
SAINT-GOBAIN

aldes

VMZINC

somfy **Eternit**

VELUX A/S
Ådalsvej 99
DK-2970 Hørsholm
Tel. +45 45 16 40 00



Bringing light to life™

VELUX®

Follow the project, visit
www.velux.com/modelhome2020

System solution

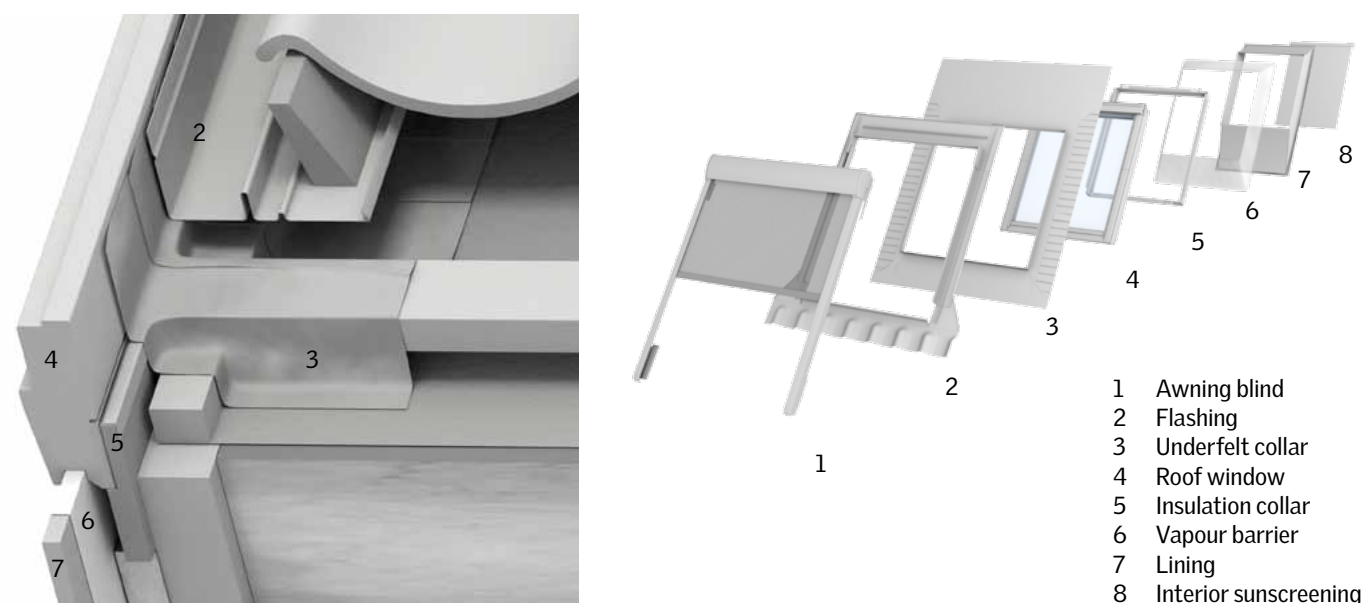

- 1 Awning blind
- 2 Flashing
- 3 Underfelt collar
- 4 Roof window
- 5 Insulation collar
- 6 Vapour barrier
- 7 Lining
- 8 Interior sunscreening

Figures

The chart shows the technical characteristics of the VELUX roof windows in relation to heat loss, passive heat gain and daylight. The heat loss (U_w) of the roof windows is influenced by the roof pitch. The heat gain (g-value) and light transmittance (τ) are not affected by the orientation or roof pitch.

Roof windows with pane --60 (south-facing) and pane --73 (north-facing)

Roof pitch	90° (pane --60 / --73)	45° (pane --60)	25° (pane --73)
U_w (Heat loss U-value window reference size)	1.3 / 1.4 W/m ² K	1.6 W/m ² K	1.7 W/m ² K
U_g (Heat loss U-value pane)	1.0 / 1.1 W/m ² K	1.3 W/m ² K	1.5 W/m ² K
g (Total solar energy transmittance)	0.29 / 0.56	0.29	0.56
τ (Light transmittance)	0.62 / 0.77	0.62	0.77

Outer walls

U (Heat loss U-value)	0.124 W/m ² K (300 mm insulation)
-----------------------	--

Roof

U (Heat loss U-value)	0.098 to 0.105 W/m ² K depending on roof pitch (500 mm insulation)
-----------------------	---

Floor slab

U (Heat loss U-value)	0.129 W/m ² K (230 mm insulation)
-----------------------	--

Fenestration

Glass area	46 m ²
Gross floor area (according to ISO 9836)	174 m ²
Net floor area (according to French national standard)	135 m ²
The window area is equivalent to 33 % of the habitable area according to French national standard.	



Project partners

nomade
architectes

étha

CARDONNEL Ingénierie
le confort durable du bâtiment

Group partners

Window Master

SONENKRAFT
forever clever

Product partners

SAINT-GOBAIN

GLASSOLUTIONS
SAINT-GOBAIN

ISOVER
SAINT-GOBAIN

SAINT-GOBAIN
SOLAR

Placo
SAINT-GOBAIN

aldes

VMZINC

somfy **Eternit**